

# PrecisionLine™

## Dual Technology Motion Sensor

### Models: RCR-A (Form A) RCR-C (Form C)



## Installation Instructions

### Description

PrecisionLine™ dual technology sensors combine range-controlled radar (RCR) technology with a passive infrared (PIR) system to increase false alarm immunity by allowing them to sense human-sized objects within a specified range. Both the RCR and PIR systems must be triggered to set off an alarm, unless in stealth mode (radar-only).

The detector is designed to use a 12VDC power supply provided by a UL Listed alarm control panel.

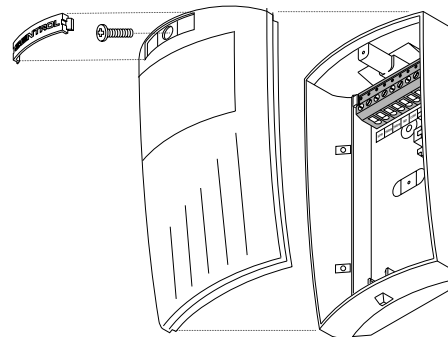

Figure 2. Detector (exploded)

### Features

The detector provides the following features:

- **Stealth Mode (radar only)** - Internal jumper allows you to disable the PIR, and use the radar only to detect intruders faster. This mode can be used for covert installations (mounted behind walls).
- **Selectable range up to 35 feet (10.7m)** - Internal jumper allows radar range selection to optimize coverage.
- **LED indicator** - A multi-color LED provides detector status.
- **Tamper switch (RCR-C only)** - Activated when the pins on the circuit board are removed from the terminal sockets on the base.

### Parts

The following parts are included with the detector:

- RCR detector
- 1 screw to join the case halves
- 3 factory-installed jumpers

### Selecting a Location for the Detector

The detector can be mounted in a corner or on a flat wall. Use the following guidelines to determine the best location to install the detector:

- Mount the detector so the expected movement of an intruder is across the detection pattern. See Figure 1.
- Mount the detector on a stable surface 7 to 9 feet (2.1 to 2.7m) high.
- **DO NOT** mount the detector within 2 feet (0.6m) of any metallic objects or within 5 feet (1.5m) of any florescent lights.
- **DO NOT** place any objects in front of the detector that may prevent a clear line of sight. Not applicable in High Security Mode (radar only).
- Avoid locations that expose the detector to possible false alarm sources such as:
  - Moving or vibrating objects (fans, pulleys, conveyor belts)
  - Electronic fields (electric motors, high voltage equipment)
  - Water spray or corrosive environments
  - Heat sources in the field of view (heaters, radiators)
  - Windows in the field of view
  - Strong air drafts on the detector (fans, air conditioners)
- When installing multiple detectors:
  - **DO NOT** mount detectors facing each other.
  - Mount them at least 20 feet (6.1m) apart.
  - Use shorter range settings to avoid overlapping radar coverage.
  - Mounting sensors back to back is not recommended, but if an application requires such mounting, use the 9-foot (2.7m) range, mount at least 1 foot (0.3m) apart, and walk test the installation to ensure proper operation.

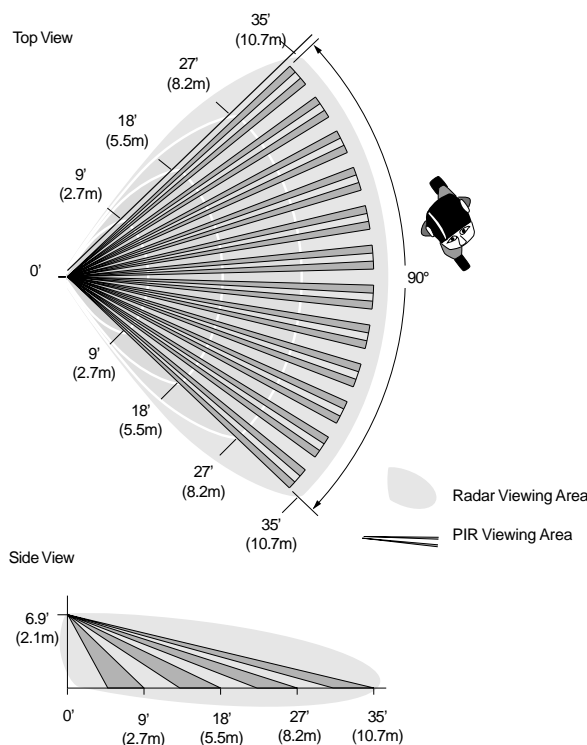

Figure 1. RCR and PIR Coverage Patterns

# Installing the Detector

All wiring must conform to National Electric Code (NEC) and/or local codes having jurisdiction.

**Important: DO NOT use this device for safety interlock applications.**

Use the following steps to install the detector:

1. Run the security system wiring to the detector location.
2. To remove the front cover/electronic module, press down on the lever at the bottom of the unit and pull the cover off. Remove the nameplate and loosen the screw if necessary. To remove the nameplate, insert a small screwdriver into one of the nameplate side slots and gently push in on the nameplate. See Figure 2.



**CAUTION**

**You must be free of all static electricity before handling sensor circuit boards. Touch a grounded, bare metal surface before touching circuit boards or wear a grounding strap**

3. If necessary, set the jumpers on the circuit board. See *Setting the Jumpers*.
4. Remove the appropriate wiring and mounting knockout holes from the back cover. The detector can be mounted on a flat wall or in a corner. See Figure 3.
5. Pull the wires through the knockout holes and use screws to attach the base to the wall. Use screw anchors if necessary.
6. Strip 1/4 inch (6.4mm) of insulation from each wire.
7. Run each wire through the strain relief and into the appropriate screw terminals on the base. Tighten the screws. See Figure 3.
8. Line up the tabs on the bottom of the cover/electronic module with the corresponding tabs on the bottom of the base and snap the cover/electronic module firmly down onto the base.
9. Tighten the screw and replace the nameplate. See Figure 2.
10. Apply power. The green LED should light for approximately 25 seconds and then go out.
11. Walk test the coverage pattern as follows:
  - Walk throughout the intended coverage area.
  - Verify the detector alarms. See *Understanding the LED*.

**Note**

Most units walk test more accurately if the person testing waits 10 seconds between tripping the unit and walking again. This allows the detector to stabilize between trips.

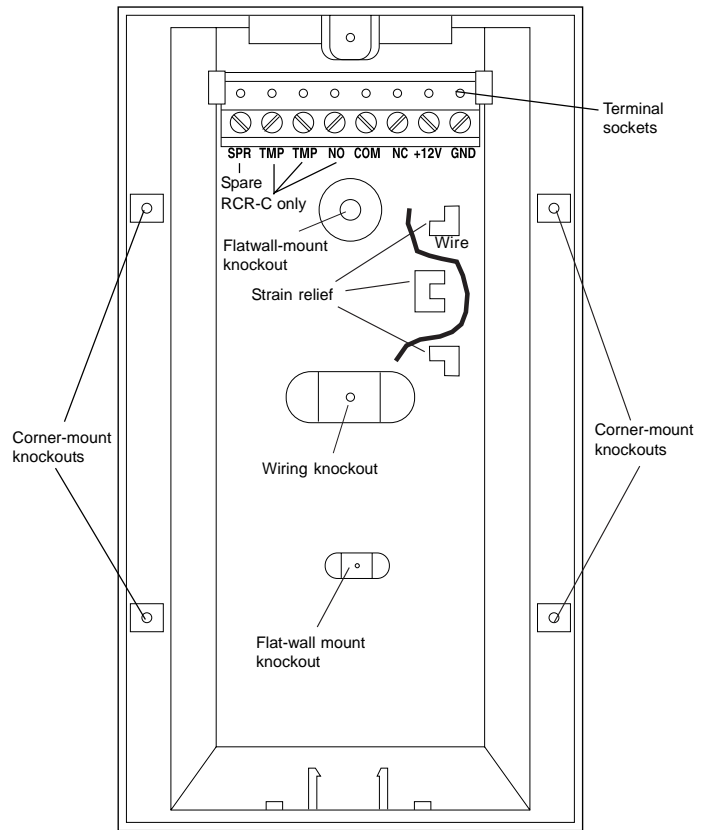

Figure 3. Detector Base

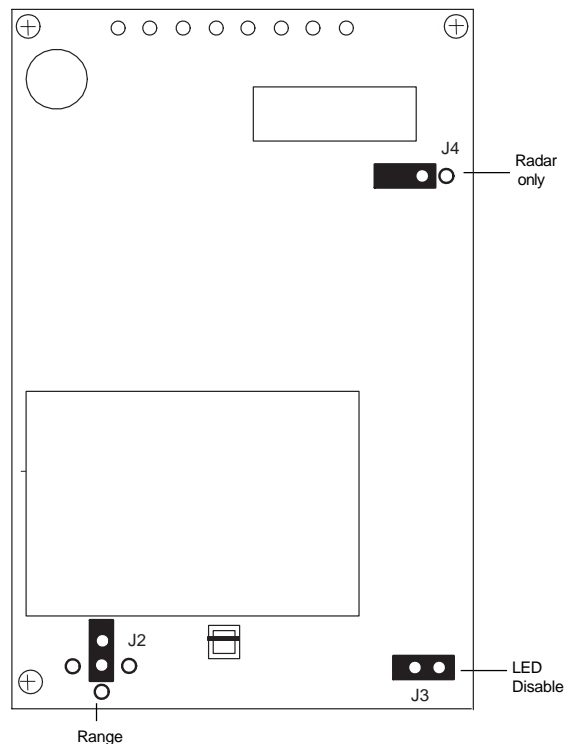

Figure 4. Main Circuit Board

## Setting the Jumpers

The detector provides jumpers to select the detection range and PIR and LED operation. See Figure 4.

**J2 Range** - Use the jumper to cover the center pin and the pin indicating the desired range. No jumper = 35 feet (10.7m) and under.

35 feet (10.7m) and under      27 feet (8.2m) and under  
**(factory default)**

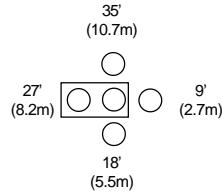
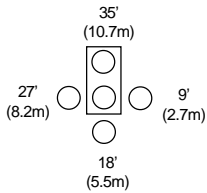

18 feet (5.5m) and under

9 feet (2.7m) and under

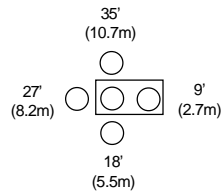
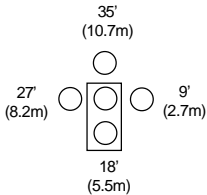

**Important:** You need to set J2 as close to the intended coverage range as possible. Overshooting the coverage area may cause false alarms.

### J3 LED -



ON = LED enabled **(factory default)**



OFF = LED disabled

### J4 PIR -



ON = Radar only enabled



OFF = PIR and radar enabled **(factory default)**

## SB01 Swivel Mount Bracket

For ceiling-mount applications that require 90 degree coverage, an optional ceiling-mount swivel bracket (SB01) is available from GE Interlogix. See Figure 5.

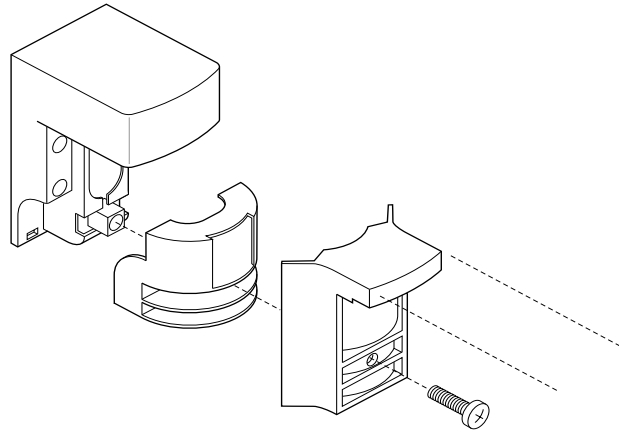

Figure 5. SBO1 Swivel-Mount Bracket

## Maintaining the Detector

When installed and used properly, the detector provides years of service with minimal maintenance. You should walk test the detector annually to ensure proper operation.

When the cover is removed, power is interrupted to the sensor. Once the cover has been replaced, the green LED will illuminate for 25 seconds while the sensor warms up. After the green LED goes off, wait one minute and walk test the sensor.

## Understanding the LED

The multi-color LED located on the bottom of the detector indicates the status of the unit as described in the following table.

LED	Status
Red	PIR and radar detection. The detector is in alarm and the relay has switched.
Green	PIR detection only (no alarm).
Yellow	Radar detection only (no alarm).

### In Stealth Mode (radar only):

LED	Status
Red	Radar detection.

## Specifications

Input voltage	8.5 to 18 VDC (UL: 10 to 16VDC)
Typical current	20mA
Maximum current	27mA
Electrical configuration	RCR-A: Form A RCR-C: Form C
Relay rating	RCR-A: 40VDC, 300mA max., 6W Load max. RCR-C: 40VDC, 150mA max., 5W Load max.
Tamper (RCR-C only)	100ma, 40VDC
Detection range	35' (10.7 m) x 90°
Target velocity	0.5 ft/sec to 5 ft/sec
Alarm duration	5 sec
Mounting height	7' to 9' (2.1m to 2.7m)
Operating temperature	32° to 122°F (0° to 50°C)
Relative humidity	5 to 93% non-condensing
Dimensions:	Width 2.8" (7.1cm) Depth 2.3" (5.7cm) Height 5.1" (13cm)
Weight	6 oz (170g)
Color	White
Field wiring size	12-24 AWG
Radar frequency	5.8GHz
Listing	C-UL US

## FCC Compliance

This device complies with Part 15 of the FCC rules. Operation is subject to the following three conditions:

- (1) This device may not cause harmful interference
- (2) This device must accept any interference received, including interference that may cause undesired operation.
- (3) Changes or modifications not expressly approved by the party responsible for compliance could void the user's authority to operate the equipment.

**FCC ID:** CGGAA2

## Product Ordering

Model Number	Description
RCR-A	PrecisionLine dual technology utilizing range-controlled radar, passive infrared technology with form A relay, stealth mode (radar only), selectable range of 9, 18, 27, and 35 feet.
RCR-C	PrecisionLine dual technology utilizing range-controlled radar, passive infrared technology with form C relay, stealth mode (radar only), tamper contacts, selectable range of 9, 18, 27, and 35 feet.
<b>Accessories</b>	
SB01	Swivel-mount bracket



**GE Security**  
12345 SW Leveton Drive  
Tualatin, OR 97062  
503-692-4052  
USA & Canada: 800-547-2556

**Tech Support**  
800-648-7424  
FaxBack: 800-483-2495  
[www.ge-security.com](http://www.ge-security.com)

1035261 Rev D 04/04